

TOTE-A-LOAD, TAL-260-DC

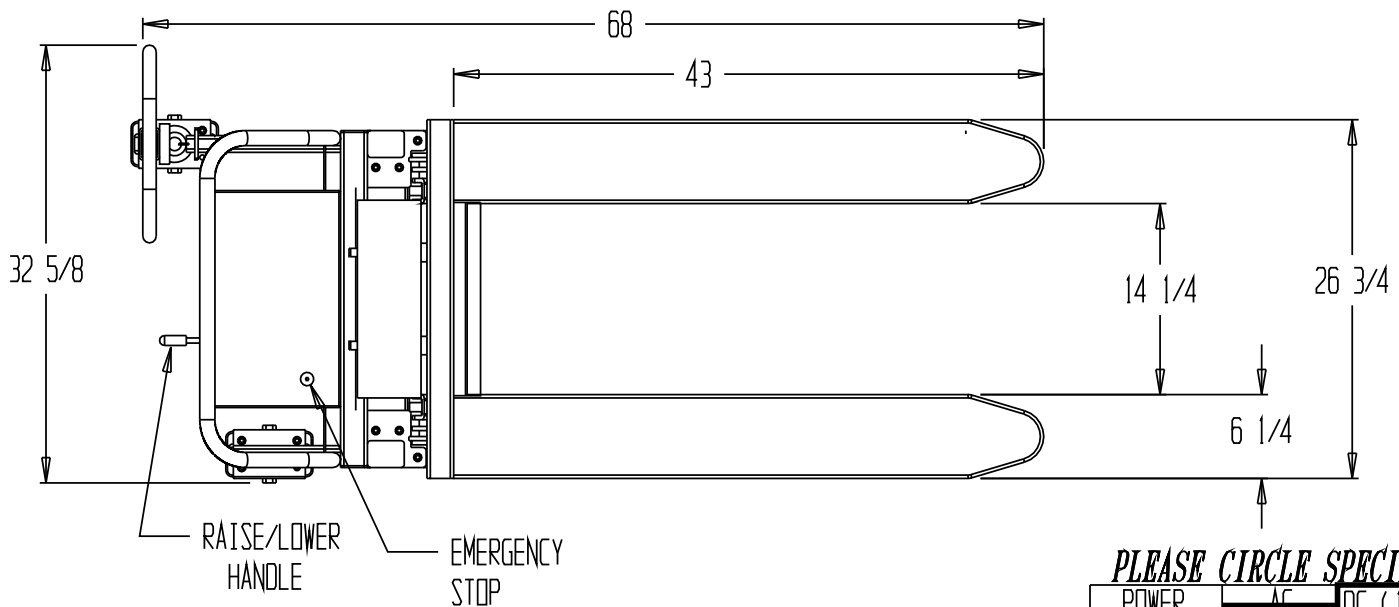

PLEASE CIRCLE SPECIFICATIONS:

POWER	<input type="checkbox"/> AC	<input checked="" type="checkbox"/> DC (12V)	<input type="checkbox"/> AIR/OIL	
MOTOR VOLTAGE	<input type="checkbox"/> 115	<input type="checkbox"/> 208	<input type="checkbox"/> 230	<input type="checkbox"/> 460
DEDICATED CIRCUIT REQUIRED				
MOTOR PHASE	<input type="checkbox"/> SINGLE	<input type="checkbox"/> THREE		
CONTROL	<input checked="" type="checkbox"/> HAND	<input type="checkbox"/> *FBBT		
* BATTERY CHRG.	<input type="checkbox"/> REMOTE	<input type="checkbox"/> ON-BOARD		
* CHRG. INDICATOR	<input checked="" type="checkbox"/> YES	<input type="checkbox"/> NO		

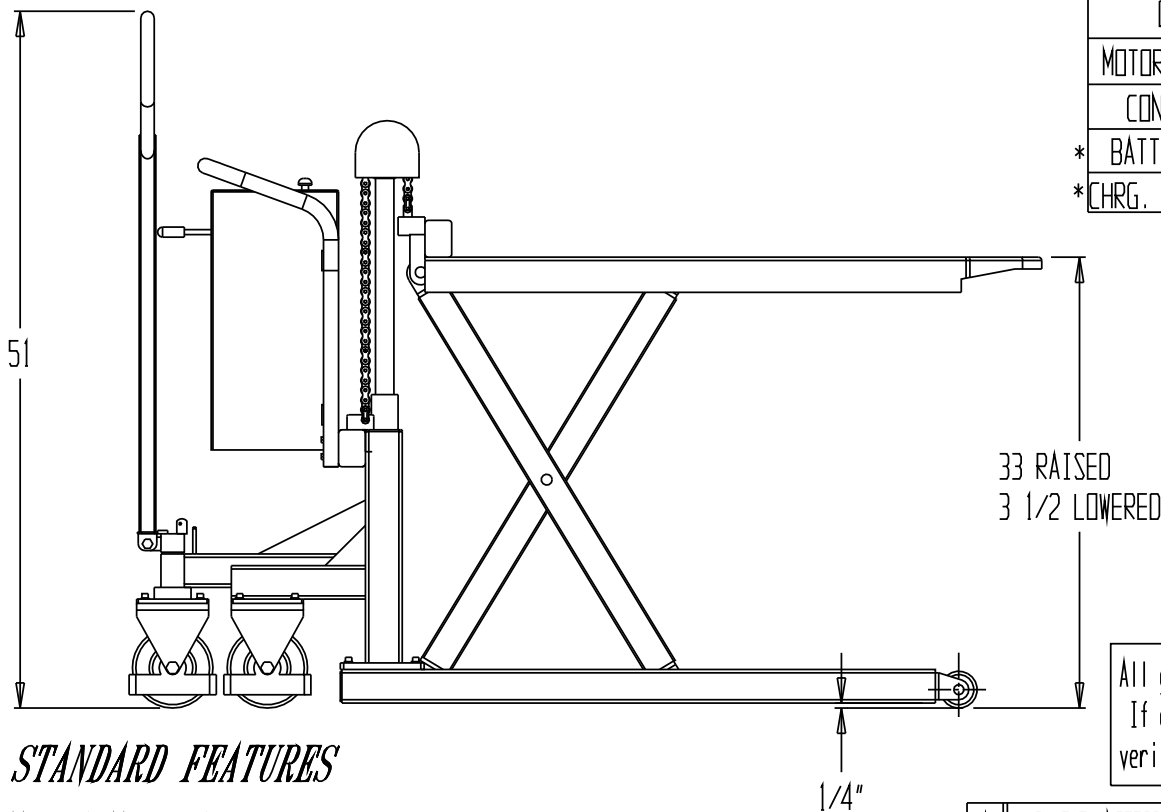

Any additions, deletions or omissions must be corrected on this drawing, as this drawing will be considered all inclusive.

All graphics provided are for reference only. If certain dimensions are critical please verify those dimensions with your salesperson

STANDARD FEATURES

- MODEL NUMBER: TAL-260-DC
- CAPACITY: 2,200 LBS.
- OVERALL WIDTH: 32 5/8"
- OVERALL LENGTH: 68"
- OVERALL HEIGHT: 51"
- RAISED FORK HEIGHT: 33"
- LOWERED FORK HEIGHT: 3 1/2"
- USABLE FORK LENGTH: 43"
- OVERALL FORK WIDTH: 26 3/4"
- INDIVIDUAL FORK WIDTH: 6 1/4"
- STANDARD 12 V DC POWERED

SPECIAL FEATURES

NONE

A P P R O V A L

I, THE UNDERSIGNED, AGREE THAT THE PRODUCT AS REPRESENTED SATISFIES DESIGN & DIMENSION REQUIREMENTS. I ALSO ACKNOWLEDGE MY DUTY TO CONFIRM PRODUCT & INSTALLATION COMPLIANCE WITH ALL APPLICABLE FEDERAL, STATE AND LOCAL REGULATIONS & STANDARDS.

ALL SPECIAL UNITS ARE NON-RETURNABLE

[] As drawn [] As marked

Signed: _____ Date: _____

LEAD TIME WILL START UPON RECEIPT OF SIGNED APPROVAL DRAWING

- **SPECIAL UNITS ARE NON-RETURNABLE
- *AVAILABLE AT ADDITIONAL COSTS

DISTRIBUTOR'S NAME: VESTIL MFG		P.O.#: -
DRAWN BY: SR		W.O.#: -
DATE: 6/4/04	SALES: -	
REFERENCE: -	SCALE: 1:15	DRWG./FILE NAME:
QUOTED LEADTIME: -	QUOTE #: -	TAL-260-DC